



Doors Price List 2012

Edition 2

Love the space you're in.

3	Conditions of Sale
4	Quick Guide to Stock Doors
5-9	Stock Doors
10-11	Made to Order Doors
12-17	Joinery
18-19	Terms and Conditions of Sale

Standard Lead Times

Stock Doors	Normally within 4 working days
Modified Stock Doors	Normally within 4 working days
Made to Order Doors	Standard Veneers normally within 10 working days
Non Standard Veneers	Normally within 14 working days

Standard stock doors are not sold as sequentially matched veneered sets. Made to Order doors can be sequentially matched on request.

In addition to the standard stock door veneers, the Made to Order door range allows the specifier complete freedom to choose any veneers that are commercially available.

Veneered doors are supplied with unlacquered concealed hardwood lippings to all edges and are colour co-ordinated to the specified veneer. Exposed lippings are available on request.

The appearance of a veneered flush door may be further enhanced to the specifiers choice by the application of hardwood mouldings or the introduction of grooves into solid wood inlays.

Standard stock and custom made doors are finished in UV cured clear lacquers.

No attempt should be made on-site to strip the lacquer and refinish. Application of stained lacquers to veneers is available on request.

All laminate manufacturers' ranges suitable for door fixings are available for Komfort's custom doors with either exposed or concealed lippings.

Door overpanels are supplied oversize to the door width to facilitate on site fitting.

Credits will not be issued for doors that have already been hung.

At the time of placing order, please supply confirmation of all special size requirements, veneers, veneer cutting, handling etc. to ensure compliance with current lead times.

Other configurations and veneer cuts are available on request.

Confirmed orders for doors cannot be cancelled

A CANCELLATION FEE OF 100% WILL BE APPLIED

Komfort Fire Door Assurance Scheme

Following the introduction of the Regulatory Reform (Fire Safety) Order on 1st October 2006 companies and individuals responsible for business premises are required to carry out a fire risk assessment.

To assist the person responsible for identifying fire protection barriers, Komfort Fire Doors are now

marked on the top edge of the door by means of a tamper proof label issued under the terms of a third party certificated fire performance scheme.

Komfort FD30 Fire Doors also carry installation instructions which should be adhered to in order to achieve the stated fire performance.

PARTITIONING SYSTEM PRE-FINISHED QUALITY VENEER DOORS - PART CODES						
Concealed Hardwood Lippings						
Classification	Standard					
Size mm					Full Height Door	Full Height Door
Type & veneer finish	762 x 1981 x 44	838 x 1981 x 44	826 x 2040 x 44	926 x 2040 x 44	838 x 2700 x 44	926 x 2700 x 44
LIGHT DUTY (Hollow Core)						
PLY - for painting		472	-	-	-	-
SAPELE	501	500	-	-	-	-
KOTO	494	490	-	-	-	-
WHITE OAK	493	475	-	-	-	-
ASH	491	466	-	-	-	-
MAPLE	-	580	-	-	-	-
STEAMED BEECH	-	579	-	-	-	-
½ HOUR FIRE PERFORMANCE HEAVY DUTY (FD30)						
PLY - for painting	-	473	5576	KD20P	-	KD27P
SAPELE	505	504	5585	KD20S	563	KD27S
KOTO	-	489	-	-	-	-
WHITE OAK	-	474	5589	KD20O	564	KD27O
ASH	-	465	5595	KD20A	566	KD27A
CHERRY	-	560	-	KD20C	572	KD27C
WHITE BEECH	-	-	-	-	-	-
STEAMED BEECH	-	577	-	KD20SB	571	KD27SB
MAPLE	-	578	-	KD20M	570	KD27M

Doors are available as non fire performance with option for Approved Document 'M' and BS 8300 vision panels code 464 or 461.S. They may be altered to suit requirement, however any adjustments to the width must be balanced i.e. reduced from both sides and an exposed lipping applied. All size alterations are subject to manufacturing restrictions and technical approval. (see page 8 for modification details).

See Joinery Services for further information.

*Ex stock items. For non listed and non stock items please ask for delivery timescale.

For Document M compliant leading edge door strip see page 9.

Hollow Core Doors

Code	Veneer Type	Veneer Finish	Door Size (mm)			Price £ each
			Height	Width	Thickness	
501*	Sapele	Book Matched St. Grain	1981	x 762	x 44	54.68
491*	Ash	Crown Cut	1981	x 762	x 44	123.68
493*	White Oak	Crown Cut	1981	x 762	x 44	123.68
494*	Koto	Half Crown Cut	1981	x 762	x 44	74.20
838mm width						
466*	Ash	Crown Cut	1981	x 838	x 44	123.68
472*	Ply (<i>for painting</i>)	–	1981	x 838	x 44	59.88
475*	White Oak	Crown Cut	1981	x 838	x 44	123.68
490*	Koto	Half Crown Cut	1981	x 838	x 44	74.20
500*	Sapele	Book Matched St. Grain	1981	x 838	x 44	54.68
579*	Steamed Beech	Crown Cut	1981	x 838	x 44	123.68
580*	Maple	Crown Cut	1981	x 838	x 44	131.47
With concealed hardwood lippings						

*Ex stock items. For non listed and non stock items please ask for delivery timescale.

Solid Core Doors achieve 1/2 hour fire performance when fitted in accordance with Komfort's Installation Instructions.

Solid Core Doors

Code	Veneer Type	Veneer Finish	Door Size (mm)			Price £ each
			Height	Width	Thickness	
505*	Sapele	Book Matched St. Grain	1981	x 762	x 44	96.34
838mm widths:						
465*	Ash	Crown Cut	1981	x 838	x 44	187.46
473*	Ply (for painting)	-	1981	x 838	x 44	70.29
474*	White Oak	Crown Cut	1981	x 838	x 44	187.46
489*	Koto	Half Crown Cut	1981	x 838	x 44	122.37
504*	Sapele	Book Matched St. Grain	1981	x 838	x 44	96.34
560*	Cherry	Crown Cut	1981	x 838	x 44	187.46
577*	Steamed Beech	Crown Cut	1981	x 838	x 44	187.46
578*	Maple	Crown Cut	1981	x 838	x 44	199.18
826mm widths:						
5585*	Sapele	Book Matched St. Grain	2040	x 826	x 44	96.34
5595*	Ash	Crown Cut	2040	x 826	x 44	187.46
5576*	Ply (for painting)	-	2040	x 826	x 44	70.29
5589*	White Oak	Crown Cut	2040	x 826	x 44	187.46
926mm widths:						
KD20A	Ash	Crown Cut	2040	x 926	x 44	216.36
KD20M	Maple	Crown Cut	2040	x 926	x 44	230.05
KD20SB	Steamed Beech	Crown Cut	2040	x 926	x 44	216.11
KD20C	Cherry	Crown Cut	2040	x 926	x 44	217.47
KD20P	Ply (for painting)	-	2040	x 926	x 44	156.87
KD20S	Sapele	Book Matched St. Grain	2040	x 926	x 44	156.60
KD20O	White Oak	Crown Cut	2040	x 926	x 44	216.44

2.7m High Solid Core Doors

Code	Veneer Type	Veneer Finish	Door Size (mm)			Price £ each
			Height	Width	Thickness	
563*	Sapele	Book Matched St. Grain	2700	x 838	x 44	252.95
564*	White Oak	Crown Cut	2700	x 838	x 44	269.00
566*	Ash	Crown Cut	2700	x 838	x 44	269.00
572*	Cherry	Crown Cut	2700	x 838	x 44	269.00
571*	Steamed Beech	Crown Cut	2700	x 838	x 44	269.00
570*	Maple	Crown Cut	2700	x 838	x 44	283.80
926mm width						
KD27A	Ash	Crown Cut	2700	x 926	x 44	286.12
KD27M	Maple	Crown Cut	2700	x 926	x 44	301.88
KD27SB	Steamed Beech	Crown Cut	2700	x 926	x 44	286.12
KD27C	Cherry	Crown Cut	2700	x 926	x 44	286.12
KD27P	Ply (for painting)	-	2700	x 926	x 44	257.77
KD27S	Sapele	Book Matched St. Grain	2700	x 926	x 44	269.04
KD27O	White Oak	Crown Cut	2700	x 926	x 44	286.12

All the following costs are exclusive of the door price.

* Price for cutting and beading aperture only. Using standard H10 Hockey Stick Bead. Other bead styles available at additional cost.

** Price includes cutting of aperture, fitting glass and lacquered glazing bead.

*** Size is subject to manufacturing capability and fire test limitations as outlined below.

Other shapes and sizes of Vision Panel, in approved types of glass, are available to order. Please ask for a quotation and delivery time.

Vision Panels

Code	Vision Panel Size (mm) Excluding Hockey Stick	Price £					
		*Aperture without Glass P	*Aperture for 1 hour with Intumescent/Beads & without Glass H	(GWPP) Fire Safety G24	**Aperture with Glass Fitted 6mm Clear Glass G1	1 hour (GWPP) Fire Safety G24/HG	Clear Komfort Fire Glass ½ hour G22
460 VP5	534 x 534	50.88	84.80	96.46	76.32	136.74	133.56
459 VP4	457 x 457	48.76	77.38	84.80	71.02	120.84	111.30
462 VP6	457(nom) dia.	166.42	n/a	210.94	183.38	302.10	215.18
458 VP2	457 x 152	44.52	65.72	65.72	56.18	90.10	69.96
463 VP3	609 x 152	46.64	72.08	69.96	63.60	97.52	78.44
461.S	***Size to Order	68.90	112.36	112.36	92.22	157.94	142.04
464 VP1	1524 x 152	63.60	100.70	100.70	83.74	143.10	128.26
508.3 VP7	3 x 152 x 152	79.50	130.38	152.64	117.66	167.48	154.76
508.5	5 x 152 x 152	132.50	216.24	252.28	195.04	278.78	255.46

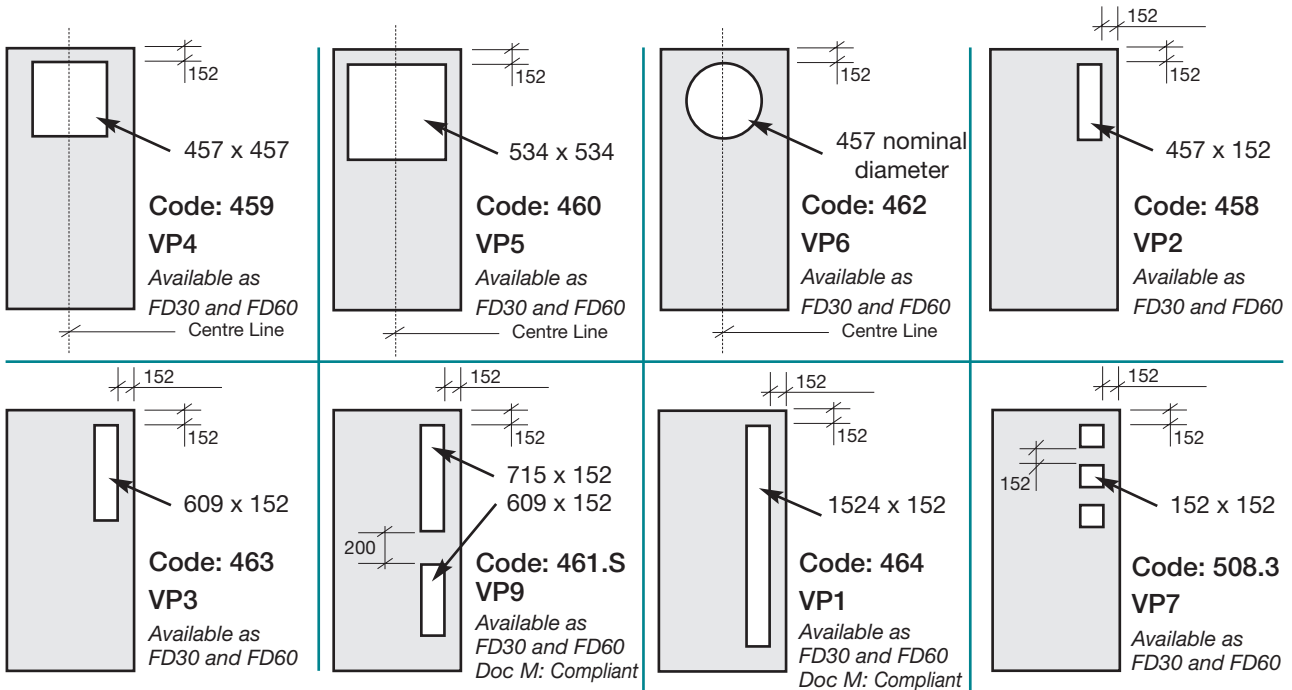

To ensure that all fire rated doors with vision panels meet the specified performance, we recommend that all doors are factory glazed.

All Komfort solid core doors with a vision panel and fitted with approved fire safety glass have been bedded in intumescent mastic and are FD30 rated and have been tested in accordance with British Standard 476: Part22: 1987. Please note that with the inclusion of the glazing bead, the visible glass size is equal to Aperture size less 30mm.

Our 1 hour fire rated vision panel in a single door uses code 567 (Pyroglaze) with the glazing beads and Georgian wired glass. Maximum 20% of door area (not to exceed 0.6m² for 54mm thick doors, not to exceed 0.2m² for 44mm thick doors). Please note that with the inclusion of the glazing bead, the visible glass size is equal to Aperture size less 50mm.

All glass fitted conforms to Document N Building Regulations and British Standards 6262, 6206 and 476 for fire resistance applications.

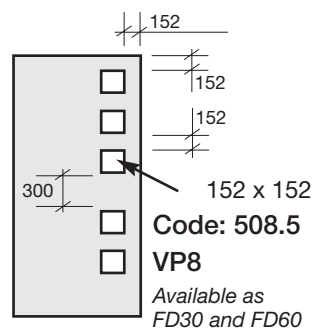

Glazing Bead

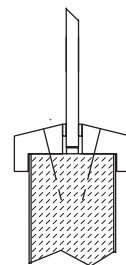

Style H10

Timber bead, square, rectangular, circular or shaped glazing detail

Approved Fire Glass				
Thickness	Brand Name	Finish	FD30	FD60
6mm	Komfort	clear	✓	
	Pyran		✓	✓
	Pyrocet		✓	
7mm	Pyrobelite	wired	✓	
	Pyroshield		✓	✓

Vision Panel Size including multi-panel design		
Door Action	FD30 Maximum Area m ²	FD60 Maximum Area m ²
latched single doors	0.80	0.60
unlatched single doors		
latched double doors	0.50	0.55
unlatched double doors		

Joinery Services - Modifications to Stock Doors

Code	Description	Price £
511	Door Reduced in width and re-lipped on one edge	77.74
511H	Door Reduced in height only	39.49
457.1	Door Grooved and fitted with intumescent strip for FD30 performance	49.36
457.2	Door Grooved and fitted with intumescent strip/ smoke seal for FD30S performance	57.99
482	Door Grooved at base for Threshold smoke seal	14.81
440	Door Milled to receive leading edge strip (see page 9) (Strip sold separately)	14.37

Leading edge door strip

to suit up to 50mm thick door

Profile	Code	Description	Price £
	4090	Leading edge door strip 900mm long x 25mm wide x 1.5mm thick 8mm radiused corners top and bottom Document M compliant <hr/> Available in basic and neutral colours Basic Colours: Buttercup Yellow (13), Coffee Brown (80), Ruby Red (33), Burgundy (30), Ultramarine Blue (53), Steel Blue (50), Forest Green (70) Neutral Colours: Pure White (99), Light Grey (97), Stone Grey (95), Anthracite Grey (92), Jet Black (90)	3.79

The full range of HEWI Ironmongery is available to order.

Komfort is able to supply doors factory machined for any/all of the following and your chosen ironmongery.

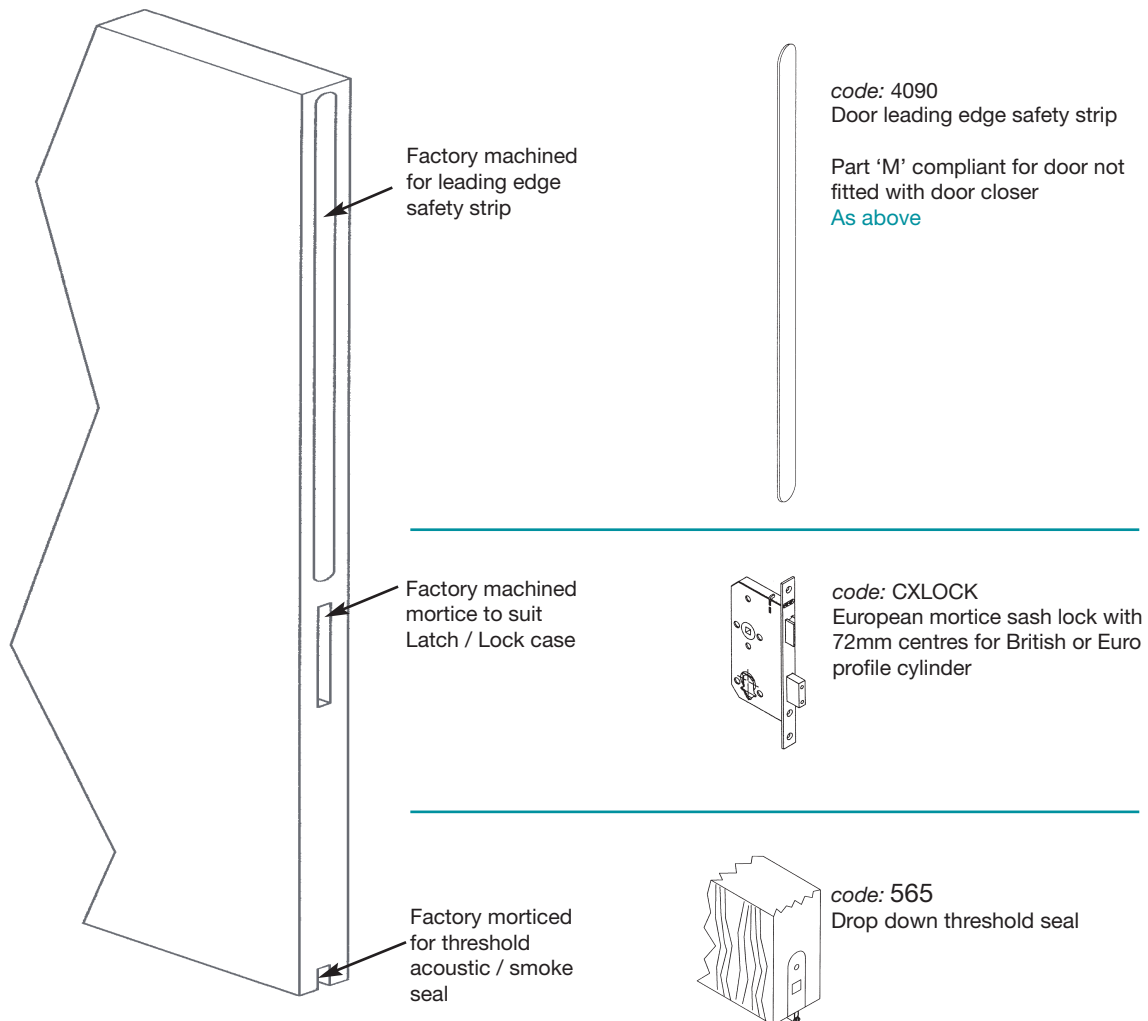

Service lead time 10 working days
Specials on application

Door Types

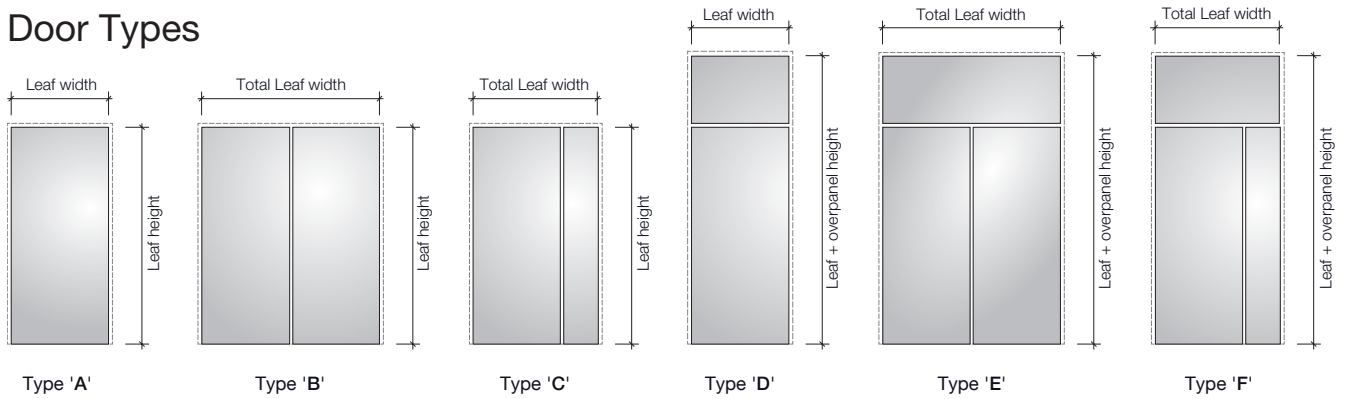

Vision Panel Options

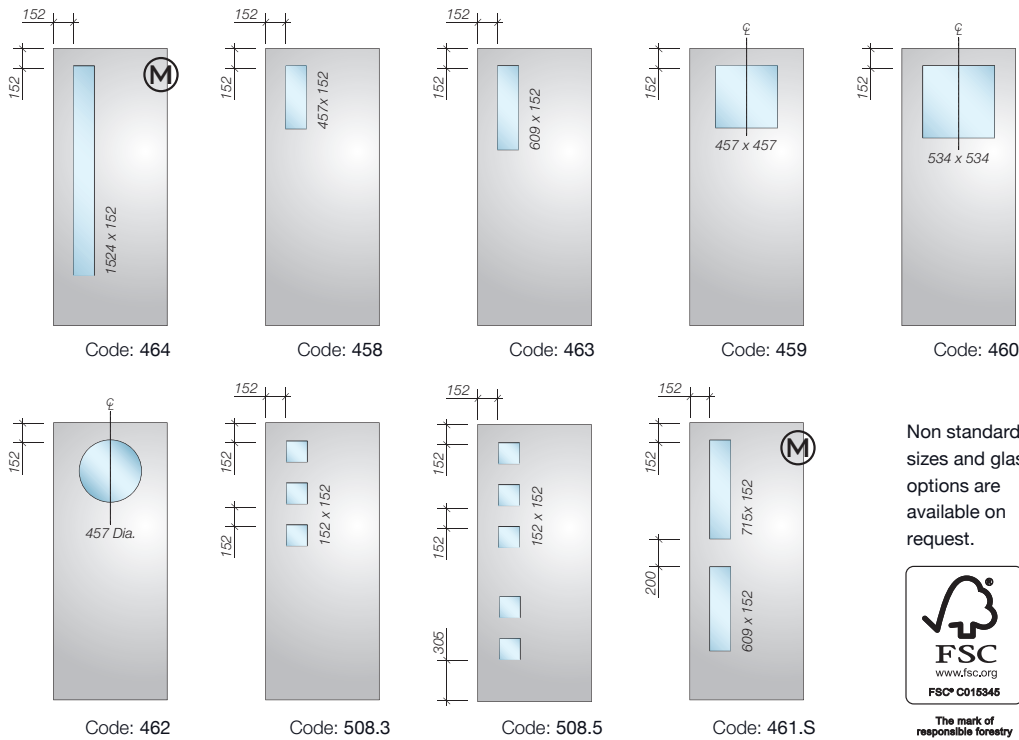

Glazing Beads

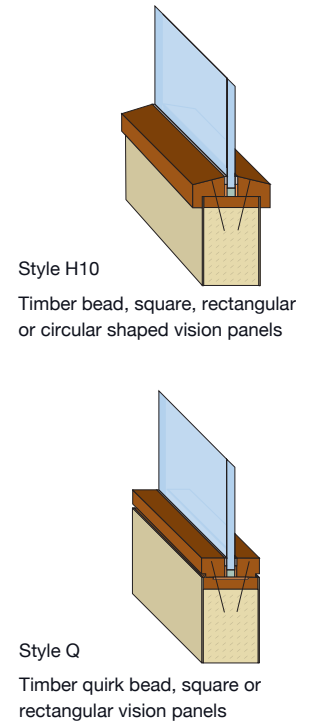

These drawings are for guidance only. For comprehensive information please contact our technical department.

Veneer finishes available

These are indicative colours only.

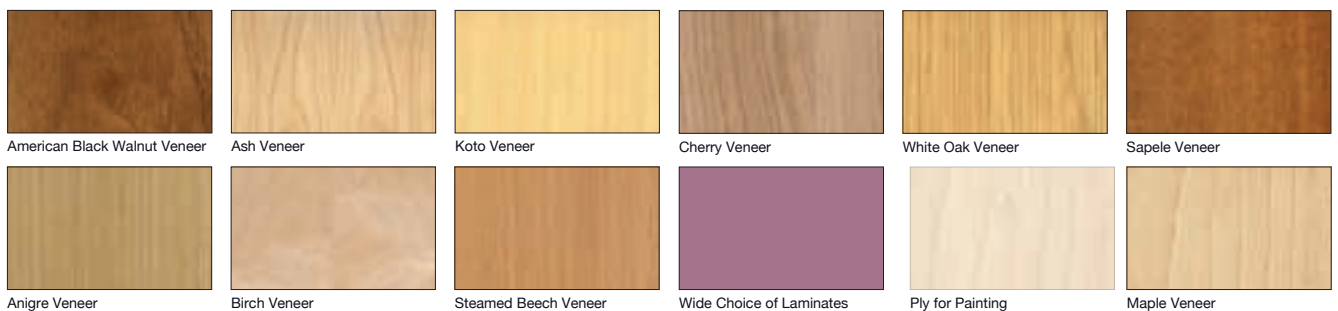



Note:

- 400 - 405 are 1 hour Fire Rated in Oak or Utile Hardwood and 1/2 hour Fire Rated in Ash, and joinery quality softwood.
- All frame kits are manufactured to suit 1981mm height doors.
- Loose stops must be pinned or screwed to obtain fire performance & Intumescent strips must be fitted in accordance with separate data sheet.
- Please contact our Technical Department for application information.

Solid timber compared to veneer naturally varies in shade. Price on application for stained to match.

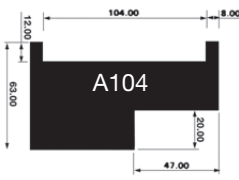
Timber Door Frame Kits (Unlacquered)

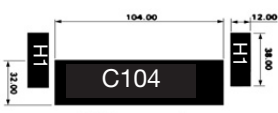
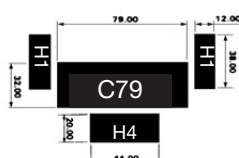
Profile	Code	Dimensions (mm)	Description	Price Per Frame £					
				Joinery quality s/wood	Utile/ Paint Grade Hardwood (Primed)	Ash	Steamed Beech	Oak	Cherry
	400-76 or 83	100	Mitred Single Door Frame	151.48	169.63	190.63	231.68	273.03	343.16
	400-15 or 16	100	Mitred Double Door Frame	181.80	203.56	228.35	278.02	327.65	411.80
	401-76 or 83	75	Mitred Single Door Frame	133.58	145.44	165.81	196.27	226.80	285.08
	401-15 or 16	75	Mitred Double Door Frame	160.29	174.53	198.95	235.53	272.17	342.09
	402-76 or 83	100	Mitred Rebated Single Door Frame Set	128.64	160.17	168.54	198.08	227.62	286.12
	402-15 or 16	100	Mitred Rebated Double Door Frame Set	154.37	192.19	202.24	237.69	273.14	343.34
	403-76 or 83	75	Mitred Rebated Single Door Frame Set	123.06	148.64	157.43	177.38	197.38	247.97
	403-15 or 16	75	Mitred Rebated Double Door Frame Set	147.67	178.38	188.90	212.85	236.85	297.56
 	404-76 or 83	100	Single Door Frame Set	110.51	135.81	136.13	145.02	153.90	193.44
	404-15 or 16	100	Double Door Frame Set	123.60	159.51	150.71	170.14	180.77	227.22
	405-76 or 83	75	Single Door Frame Set	91.77	128.94	122.37	136.79	144.66	181.81
	405-15 or 16	75	Double Door Frame Set	107.79	151.42	143.74	160.66	169.89	213.53
	STD507.83 (For use with Polar System)			Single Door Frame Set	-	180.07	190.91	205.07	282.09
STD507.16 (For use with Polar System)			Double Door Frame Set	-	205.03	217.41	233.59	321.63	355.48

The following special Profiled Joinery Kits can be made up by selecting from our Timber Sections shown on page 16.



Single Action
Single or Double Door Frame Set incorporating Architrave for Komfire 75 & 100

Double Action
Single or Double Door Frame Set with loose Architrave (requires Helical Hinges) for Komfire 75 or 100

Double Action
Single or Double Door Frame Set incorporating Architrave (requires Helical Hinges) for Komfire 75 or 100

Double Action
Single or Double Door Frame Set with loose Architrave (requires Heel Spring) for Komfire 75 or 100

Single or Double
Door Frame Set for 600 Series









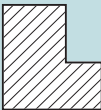

Single Glazed
Non-Fire Rated Window Lining Set for Komfire 75 or 100

Double Glazed
Non-Fire Rated Window Lining Set for Komfire 75 or 100

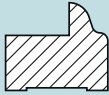
Single or Double
Sliding Door Set for 600 Series









Joinery sections are available in pre-lacquered finish at an extra over charge of £1.50 per linear metre per individual section. Solid timber compared to veneer naturally varies in shade. Price on application for stained to match.

Timber Sections (Unlacquered)

Profile	Code	Description	Dimensions (mm)	Price Per Metre £					
				Joinery quality s/wood	Utile/ Paint Grade Hardwood (Primed)	Ash	Steamed Beech	Oak	Cherry
	A79	Door Frame for 75mm Komfire Partition <i>1/2 hour fire rated in oak, utile, ash and joinery quality softwood</i>	95 x 63	26.72	29.09	33.17	39.25	45.36	57.02
	A104	Door Frame for 100mm Komfire Partition <i>1 hour fire rated in oak or utile hardwood and 1/2 hour fire rated in ash and joinery quality softwood</i>	120 x 63	30.29	33.93	38.06	46.33	54.61	68.64
	B79	75mm Door Frame Section <i>1/2 hour fire rated in oak, utile, ash and joinery quality softwood</i>	79 x 52	17.80	22.01	23.50	27.01	30.50	38.32
	B104	100mm Door Frame Section for 44mm Door104 x 52 <i>1 hour fire rated in oak or utile hardwood and 1/2 hour fire rated in ash and joinery quality softwood</i>	104 x 52	18.91	24.32	25.74	31.15	36.54	45.95
	B105	100mm Door Frame Section for 54mm Door104 x 52 <i>1 hour fire rated in oak or utile hardwood and 1/2 hour fire rated in ash and joinery quality softwood</i>	104 x 52	18.91	24.32	25.74	31.15	36.54	45.95
	B106	Profiled Door Frame for 75mm Komfire Partition To suit 44mm thick doors only <i>1/2 hour fire rated in oak, utile, ash hardwoods and joinery quality softwood</i>	96 x 63	31.70	41.83	45.42	50.80	56.18	70.62
	B107	Profiled Door Frame for Klassic Partition To suit 44mm thick doors only <i>1/2 hour fire rated in oak or utile hardwoods and quality joinery softwood</i>	78 x 67	18.88	24.13	22.08	24.76	31.63	38.02
	B206	Profiled Door Frame for 100mm Komfire Partition To suit 54mm thick doors only <i>1 hour fire rated in oak or utile hardwood and 1/2 hour fire rated in ash and joinery quality softwood</i>	120 x 63	39.62	52.27	56.77	63.50	70.23	88.27
	C79	75mm Door Frame or Window Lining for <i>1/2 hour fire application</i>	79 x 32	7.46	9.56	9.66	10.26	10.87	13.65
	C104	100mm Door Frame or Window Lining for <i>1/2 hour fire application</i>	104 x 32	7.94	10.72	10.87	12.35	13.85	17.42
	D79	75mm Wall End Capping Double Action Door Frame Head Fixed Architrave	95 x 45	16.23	20.39	20.73	22.09	23.45	29.48
	D104	100mm Wall End Capping Double Action Door Frame Head Fixed Architrave	120 x 45	17.63	23.03	23.72	25.49	27.23	34.19









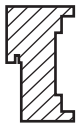

Joinery sections are available in pre-lacquered finish at an extra over charge of £1.50 per linear metre per individual section. Solid timber compared to veneer naturally varies in shade. Price on application for stained to match.

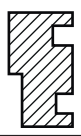
Timber Sections (Unlacquered)

Profile	Code	Description	Dimensions (mm)	Price Per Metre £					
				Joinery quality s/wood	Utile/ Paint Grade Hardwood (Primed)	Ash	Steamed Beech	Oak	Cherry
	E79	75mm Door Frame for Double Action Heel Spring	79 x 42	12.59	17.00	17.72	19.13	20.54	25.82
	E104	100mm Door Frame for Double Action Heel Spring	104 x 42	13.99	19.68	20.66	22.48	24.33	30.56
	H1	Architrave	38 x 12	3.41	3.87	3.99	4.23	4.48	5.64
	H2	Architrave	54 x 12	4.22	4.65	4.78	5.13	5.49	6.90
	H3	Door Stop	30 x 25	3.74	4.58	4.67	4.88	5.09	6.40
	H4	Door Stop	44 x 20	4.43	5.00	5.17	5.85	6.54	8.20
	H5	Glazing Bead	12 x 12	3.05	3.18	3.41	3.56	3.74	4.71
	H6	75mm Double Glazing Cavity Bead	12 x 18	3.25	3.39	3.63	3.76	3.91	4.92
	P279	75mm Door Frame for Single Glazed Polar <i>Non-fire rated</i>	94 x 55	26.72	29.09	33.17	39.25	45.36	57.02

Joinery sections are available in pre-lacquered finish at an extra over charge of £1.50 per linear metre per individual section. Solid timber compared to veneer naturally varies in shade. Price on application for stained to match.

Timber Sections (Unlacquered)

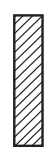
Profile	Code	Description	Dimensions (mm)	Price Per Metre £					
				Joinery quality s/wood	Utile/ Paint Grade Hardwood (Primed)	Ash	Steamed Beech	Oak	Cherry
	P281	Timber Door Frame for 75mm Solid Partition <i>Non-fire rated</i>	94 x 55	21.16	26.79	23.72	25.93	33.87	39.06
	P280	Door Frame for Double Glazed Polar <i>Non-fire rated</i>	94 x 55	19.38	25.02	21.94	24.16	32.09	37.32
	P280F	Profiled Door Frame for Double Glazed Polar 1/2 hour fire performance	58 x 104	19.16	25.38	21.99	24.43	33.16	38.90
	STD501	Door Frame for Double Glazed Polar (54mm door) <i>Non-fire rated</i>	122 x 65	23.44	31.55	28.42	32.50	42.97	52.71
	H7	100mm Double Glazing Cavity Bead	12 x 28	3.43	3.63	3.89	4.03	4.18	5.25
	H9	Support Post for X250 Sliding Hatch	50 x 50	12.87	14.17	14.49	15.29	16.08	20.21
	H10	Hockey Stick Glazing Bead	25 x 18	-	5.88	5.97	6.57	7.17	9.01
	H11	Angled Glazing Bead 1/2 hour fire performance (for use with C71 & C104 liners)	25 x 30	3.74	4.58	4.67	4.88	5.09	6.40
	H12	Slamming Post for Sliding Doors	50 x 70	8.32	10.28	14.09	16.79	19.50	24.51
	W79	75mm Window Liner (Non fire performance)	79 x 22	8.59	9.43	9.70	10.20	10.67	13.43
	W104	100mm Window Liner (Non fire performance)	104 x 22	9.14	10.04	10.28	11.12	11.99	15.06

Softwood

Code	Description	Dimensions (mm)	Price Per 3 Metre Length £	
			Sawn & General Purpose	PAR
325	Infill for 628 Door Frame - see pages 11 & 12	43 x 22	4.97	-
326.816	Infill for 816 Door Frame - see pages 22 & 23	76 x 12.5	4.86	-
326.826	Infill for 826 Door Frame - see pages 26	101 x 12.5	5.68	-
330	Abutment Infill	46 x 11	4.09	-
331	Sawn for Door Frame 2" Stud (853) - see pages 16 & 2944 x 25		5.90	8.15
332	Sawn for Door Frame 3" Stud (878) - see pages 16	69 x 30	11.08	12.84
336	General Purpose	50 x 50	12.03	13.72
337	General Purpose	50 x 25	10.44	11.69
354	Softwood Door Aperture Infill	36 x 19	7.61	-
391	Softwood for Sliding Door Pelmet	70 x 22	-	9.87

Terms & Conditions of Sale

Please retain for your records

Interiors Manufacturing Limited trading as Komfort Workspace

Registered Office:
Cunard House
Regent Street
London SW1Y 4LR
Registered in England 07693359

1. DEFINITIONS

- 1.1 In these "Terms"
"We" and "Us" means the company specified in our quotation or order acknowledgement.
- "You" means the person, firm or company through their employees or agents seeking to purchase Goods from Us and "Your" shall be interpreted accordingly.
- "Goods" means the Goods and/or services to be supplied by Us.
- "Company Signatory" means a manager employed by Us.
- "Terms" means these terms and any special terms agreed in writing between a Company Signatory and You.
- "Consumer" means any natural person acting for purposes outside their trade, business or profession or as defined by the Unfair Contract Terms Act 1977.
- "Glass Goods" means goods to be supplied by Us made predominantly from glass and including glass doors and glazed partitions.
- "Decorative Film" means a film to be applied to the Glass Goods that provides a decorative pattern to the surface of the Glass Goods that is greater than the requirements of the Disability Discrimination Act 1995.
- "Disclaimer" means the disclaimer that We requested You sign if You required a Decorative Film to be placed on the Glass Goods.

SAFETY INFORMATION ABOUT THE USE OF THE GOODS IS PROVIDED AND IT IS YOUR RESPONSIBILITY TO BRING THIS TO THE ATTENTION OF THE USER OF THE GOODS.

2. THE CONTRACT

- 2.1 All orders are accepted by Us only under these Terms which may not be altered except with the written agreement of a Company Signatory. Any contrary or additional terms unless so agreed are excluded. In the case of You trading with Komfort Glass Division additional terms and conditions will be provided to You where appropriate, in those circumstances the Komfort Glass Division terms will form part of these Terms and no additional confirmation is required from Us for the Komfort Glass Division terms to become binding on You.
- 2.2 Quotations and tenders do not constitute offers and We may withdraw or amend them at any time before they are accepted. If We withdraw a quotation or tender We will do so in writing. All quotations and tenders are automatically withdrawn on the 90th day after their date without requirement of notification in writing.
- 2.3 We shall not be liable for any misrepresentation including any statement in any quotation or tender made by Us Our employees or agents to You as to the condition of the Goods their fitness for any purpose or as to specification, quantity or measurements unless the representation is made or confirmed in writing by a Company Signatory and/or is fraudulent. Our brochures and other literature are for Your guidance only and (in the absence of fraud on Our part) shall not constitute representations by Us.
- 2.4 Quotations and tenders have been prepared based upon information supplied by You and You are responsible for the accuracy and sufficiency of that information. You must check and confirm all measurements, sizes and quantities. We shall not be liable under Clause 2.4 or otherwise if material information is withheld concealed or misrepresented by You, Our decision as to what is material information is final.
- 2.5 Our quotations and tenders are calculated using total linear meterage divided by stock lengths. You should expect a normal wastage factor.
- 2.6 We may make changes to the specification of the Goods necessary to conform to any applicable statutory or EC requirements or where the Goods are supplied to Our specifications and the changes do not materially affect their quality or performance without having to provide you with prior notice.
- 2.7 We may charge You an extra sum for any site visits and abortive or excessive numbers of tenders prepared.
- 2.8 Orders may be cancelled only with the written agreement of a Company Signatory and You will indemnify Us against all losses damages costs and expenses We incur as a result of that cancellation. Unused Goods will be accepted for return at Our discretion and on terms agreed with Us.
- 2.9 The Parties intend that We should be able to enforce the Terms subject to and in accordance with the provisions of the Contracts (Rights of Third Parties) Act 1999.

- 2.10 It is Your responsibility to check the accuracy of Our written acceptance of the order is correct. Any discrepancy between Your order and Our acceptance must be notified to Us in writing within 5 working days of the date of such acceptance. In the absence of such notification We shall be entitled to supply Goods in accordance with the acceptance, and you shall be obliged to pay the agreed contract price thereof.

3. SPECIFICATION CHANGES

- 3.1 We reserve the right to make any alteration in the specification or design of any Goods without notice and to deliver Goods conforming to the altered specification or design in fulfillment of any order for Goods provided that the Goods delivered are suitable for general use or for such specific purpose of which You have given written notice to Us.

4. PRICE

- 4.1 The ex-works price exclusive of VAT of the Goods shall be as at the date of despatch and We may alter prices quoted or stated to take account of any increase in costs sustained by Us after acceptance of Your order. A separate charge may be made for each delivery and for packing. Any discounts deductions or rebates agreed are only available if the price is paid in full by the due date.
- 4.2 Prices stated or quoted are applicable to the quantity specification delivery dates and information provided by You. If the order placed varies or delay is caused by Your instructions or lack of instructions We shall be entitled to adjust the price.
- 4.3 The price quoted as payable for the Goods is based upon the manufacture of the Goods being carried out during Our normal working hours (which are from 7:30am to 4:30pm Monday to Thursday inclusive and from 7:30am to 12:30pm on Friday). If You require Us to work outside these hours We shall be entitled to charge You for all overtime worked at the rate to be notified in advance to You in writing.

5. ADDITIONAL COSTS

- 5.1 You agree to pay for any loss or extra cost incurred by Us through Your instructions or lack of instructions or through failure or delay in taking delivery or through any act or default on Your behalf, Your servants, agents or employees.
- 5.2 We reserve the right to make an additional charge for any extras ordered by You and not specified in the quotation and also for the expense of all inspections, tests, alterations or additions or any other work undertaken at Your request. In particular, but without prejudice to the generality of the foregoing, We may impose a charge for inspecting and/or testing Goods alleged by You to be defective or not in compliance with their contractual description, if We determine that the Goods are not defective and/ or do not comply with their contractual description and/or any defects are not the responsibility of Us under the terms of the contract.

6. PAYMENT

- 6.1 If We have agreed in writing to give You credit, all accounts are due for payment into Our bank account without deduction or retention on the last day of the month following the month in which the Goods are delivered. Time for payment shall be of the essence.
- 6.2 Credit is granted and may be reviewed at any time at Our discretion. We reserve the right to refuse to execute any order or contract if the arrangements for payment or Your credit rating is not satisfactory to Us. You shall be liable for any loss, damage or expense arising out of any withdrawal or reduction of credit or refusal to supply further Goods in accordance with this clause including any loss, damage or expense suffered by Us.
- 6.3 You may not withhold payment of any invoice or other amount due to Us by reason of any right of set off or counterclaim which You may have or allege to have for any reason.
- 6.4 Without prejudice to the Conditions hereof, if You wish to raise any queries concerning an invoice rendered by Us to You, You must provide a written query to Our Credit Control Department within seven days of the date of the invoice via email or post.
- 6.5 If You fail to give notice in accordance with 6.4 above concerning an invoice rendered by Us to You then You will be bound to accept and pay the invoice accordingly.

7. DELIVERY

- 7.1 Delivery shall occur when the Goods arrive at the delivery address or 2 working days after delivery or collection is offered to You.
- 7.2 If You fail to take or make arrangements to accept delivery or collect the Goods or We are unable to deliver because of inadequate access or instructions delivery shall be deemed to have taken place and We may do any one or more of the following (without prejudice to any other right or remedy We may have):-
- make additional charges for failed delivery
 - store the Goods at Your risk and cost
 - invoice You for the Goods
 - suspend or terminate this contract without liability on Our part
 - recover from You all costs and losses incurred by Us
- 7.3 Delivery dates are given in good faith but are estimates only. Time for delivery shall not be of the essence.

- 7.4 Standard lead times vary according to product. Time estimates will be revised on receipt of Your order and times will not run until we are in receipt of all information required from You including Your written approvals as requested by Us.

- 7.5 We shall not be liable for any damages whatsoever whether direct or indirect (including for the avoidance of doubt any liability to any third party) resulting from any delay by Us in delivery of the Goods or failure to deliver the Goods in a reasonable time where such delay or failure is beyond Our reasonable control.

- 7.6 We reserve the right to make delivery by instalments and tender a separate invoice in respect of each instalment. Any claim which You may have in respect of one instalment shall not affect Your liability in respect of any other instalment.

- 7.7 You will indemnify Us in respect of all losses damages costs and expenses incurred as a result of delivery in accordance with Your instructions. This indemnity will be reduced in proportion to the extent that such losses damages costs or expenses are due to Our negligence.

- 7.8 The risk in the Goods shall pass to You on delivery as set out in Clauses 5.1 & 5.2 above even if We have agreed to install the Goods. It is Your responsibility to ensure that the Goods are kept safe on site before, during and after installation and are fully insured against fire theft damage and other normal insurance risks for their full replacement costs.

- 7.9 Where goods are handed to a carrier for carriage to You or to United Kingdom port for export any such carrier shall be deemed to be an agent of Us and not of You for the purposes of sections 44, 45 and 46 of the Sale of Goods Act 1979.

- 7.10 Without prejudice to any other provisions of the Terms You shall not have the right to reject any item of Goods if You:
- ask Us to repair the same or consents for Us to do so
 - resell such item.

8. INSPECTION

- 8.1 You shall inspect the Goods at the place and time of unloading but nothing in these Terms shall require You to break packaging and/or unpack Goods which are intended to be stored before use.

- 8.2 Unless You advise Us by telephone immediately and written notice is received by Us within 7 working days of unloading or the date of the invoice for non delivery of any claim for loss damage short delivery or failure to conform to the contract apparent on inspection the Goods will be deemed to have been delivered in accordance with the delivery documents and You shall not be entitled to waive any right to reject the Goods.

- 8.3 Our liability for loss damage short delivery or failure of the Goods to conform to the contract which is apparent on inspection is limited to supplying the Goods as ordered or crediting part of the purchase price and We shall not be liable for any damages whatsoever. You remain liable to pay the full invoice price of Goods delivered in accordance with the contract. Any other claim for damages is subject to Clause 11.

9. TITLE

- 9.1 The title to the Goods shall remain with Us until You pay the price of the Goods in full and any other sums outstanding between You and Us whether in respect of this contract or otherwise.

- 9.2 Until title passes:-

- 9.2.1 You shall hold the Goods as Our fiduciary agent and bailee
- 9.2.2 The Goods shall be stored separately from any other goods and You shall not interfere with any identification marks labels batch numbers or serial numbers on the Goods

- 9.2.3 We agree that You may use or agree to sell the Goods as principal and not as Our agents in the ordinary course of Your business subject to the following express conditions:-

- that You notify Your customer that We remain the legal owner of the Goods until We receive payment in accordance with Clause 9.1 and We reserve the right to label the Goods accordingly
- that You will at Our request and at Your expense assign to Us all rights You may have against Your Customer; and
- that Your right to use or sell the Goods may be withdrawn by Us on notice at any time and will automatically cease in the event of Your becoming Insolvent.

- 9.2.4 If Goods are to become affixed to any land or building You must ensure that they are capable of removal without material injury to the land or building and You shall take all necessary steps to prevent title to the Goods from passing to the owner or landlord of such land or building.

- 9.3 We shall be entitled at any time to recover any or all of the Goods to which We have title and for that purpose Our employees or agents may with such transport as is necessary enter upon any premises occupied by You or to which You have access and where the Goods may be or are believed to be situated.

10. **INSTALLATION**
- 10.1 Where We have agreed to install the Goods, unless otherwise stated We assume the installation is to be carried out at ground floor level or adequate elevators, lifts or hoists are provided by You to move the Goods efficiently and safely to the place of installation and you must ensure that:
- (a) adequate access of the relevant size for the Goods is provided
 - (b) the site is ready at the agreed time for installation to commence
 - (c) the programme of works allows for installation to be completed within normal working hours
 - (d) access to the site is available at the times necessary to complete installation
 - (e) Our installation will not be delayed nor interrupted
 - (f) adequate lighting heating and power supplies are provided
 - (g) carpets, furniture and other vulnerable items are protected; and
 - (h) a safe and appropriate working environment in accordance with the British Standard Code of Practice for safe working in occupied and unoccupied parts of the site is provided for Our employees and agents.
- 10.2 If (in Our sole discretion) any of the above Conditions are not met We shall be entitled (without prejudice to any other right or remedy We may have) to:
- (a) immediately suspend Our obligation to install the Goods without liability on Our part and if the Conditions are not met within a further 7 working days thereafter cancel Our obligation to install and recover from You all losses damages costs and expenses incurred including any claims by any Third Party; and/or
 - (b) charge You for additional costs incurred in completing the installation including but not limited to travel and overtime rates for labour.
- 10.3 If We agree to undertake the installation of Goods supplied by Us we reserve the right to instruct or employ a sub contractor of Our choice for that purpose.
- 10.4 We will not be responsible for faults resulting from the incorrect installation of equipment by You, Your representatives or agents. In such a case it is Your responsibility to commission and test the installation and to arrange at Your cost for any faults to be rectified.
11. **LIABILITIES**
- 11.1 In this Clause "the Defect" shall mean the condition and/or any attribute of the Goods and/or any condition or circumstance arising from Our installation of the Goods or any other service provided by Us and/or any other circumstances which but for the effect of these Terms would have entitled You to damages.
- 11.2 Nothing in these Terms shall exclude or restrict Our liability for death or personal injury resulting from Our negligence or Our liability for fraudulent misrepresentation.
- 11.3 If You deal as a Consumer any provision of these Terms which is of no effect shall not apply. The statutory rights of a Consumer are not affected by these Terms.
- 11.4 Subject to Clauses 11.2 & 11.3 of these Terms We shall not be liable by reason of any misrepresentation (unless fraudulent) or in contract tort (including negligence or breach of statutory duty) or otherwise howsoever and whatever the cause for any damages whatsoever. Instead of liability in damages We undertake liability under Clause 11.5 below.
- 11.5 Where but for the effect of Clause 11.4 of these Terms You would have been entitled to damages against Us We shall not be liable to pay damages but subject to the conditions set out in Clause 11.6 below shall at Our sole discretion either repair the Goods at Our own expense or supply replacement Goods or re-install the Goods free of charge or refund all (or where appropriate part) of the price paid.
- 11.6 We will not be liable under Clause 11.5:
- (a) if the Defect would have been apparent on a reasonable inspection under Clause 8.1 of these Terms at the time of unloading unless You give Us written notice within 7 working days of the time of unloading.
 - (b) unless the Defect is discovered within 12 months from the date of delivery and we are given written notice of the Defect within 7 working days of it being discovered.
 - (c) unless after discovery of the Defect We are given a reasonable opportunity to inspect the Goods before they are used or in any way interfered with. We acknowledge that the costs of suspending works are relevant to the determination of what is a reasonable opportunity and this sub clause shall not apply to any works affecting the Goods which are reasonably necessary in the interests of safety and/or as emergency measures.
 - (d) if the Defect arises from fair wear and tear
 - (e) if the Defect arises from Your negligence misuse alteration or repair of the Goods storage of the Goods other than at room temperature or in any other unsuitable conditions or abnormal working conditions; and/or
 - (f) if the Defect is caused by Your or any third party's failure to assemble the Goods in accordance with Our prescribed methods and our technical information brochures.
- 11.7 If the Goods or a component in the Goods ("the Component") are not manufactured by Us or have been processed by a third party whether at Our or Your request Our liability in respect of any defect in workmanship or materials of the Goods or the Component will be limited to such rights against the manufacturer or the third party as We may have in respect of those Goods or that Component.
- 11.8 If the Goods are supplied manufactured or processed to the drawing design measurement or specification provided by You then:-
- 11.8.1 Subject to Clauses 11.2 & 11.3 of these Terms We shall not be under any liability for damages whatsoever or under Clause 11.5 of these Terms as the case may be except in the event of:
- (a) fraudulent misrepresentation by Us
 - (b) misrepresentation where the representation was made or confirmed in writing by a Company Signatory
 - (c) non-compliance with such drawing design measurement or specification; or
 - (d) breach of a written warranty signed by a Company Signatory that the Goods are fit for that purpose
- 11.8.2 You will unconditionally fully and effectively indemnify Us against all losses damages costs and expenses awarded against or incurred by Us in connection with or paid or agreed to be paid by Us in settlement of any claim:-
- (a) for infringement of any patents copyright design trademark or any other industrial or intellectual property rights of any other person; and/or
 - (b) arising from any such manufacturing or processing including but not limited to any Defect in the Goods. This indemnity will be reduced in proportion to the extent that such losses damage costs and expenses are due to Our negligence.
- 11.9 Subject to Clauses 11.2 & 11.3 We shall not be liable for misrepresentation (unless fraudulent) or in contract tort (including negligence or breach of statutory duty) or otherwise howsoever and whatever the cause thereof:-
- (a) any loss of profit, business, contracts, revenues or anticipated savings; and/or
 - (b) any special, indirect or consequential damage of any nature whatsoever.
- 11.10 Except where You deal as a Consumer You will unconditionally fully and effectively indemnify Us against all losses damages penalties costs on an indemnity basis and expenses awarded against or incurred by Us in connection with or paid or agreed to be paid by Us in settlement of any claim by any third party arising from the supply or use of the Goods. This indemnity will be reduced in proportion to the extent that such losses damages penalties costs and expenses are due to Our negligence.
- 11.11 Without prejudice to any other provision of these Terms in any event Our total liability for any claim or for the total of all claims arising from any act or acts of default on Our part (whether arising from Our negligence or otherwise) shall not exceed the purchase price of the Goods the subject matter of any claim or the limit of liability laid down by Our insurers in respect of such claim, whichever is the higher.
- 11.12 We shall not be liable for imperfect work caused by any inaccuracies in any drawings, bills of quantities or specifications supplied by You.
- 11.13 Nickel sulphate is a naturally occurring product and We shall not be liable for any damage that may occur as a result of nickel sulphate being present in Our Goods.
12. **DEFAULT & TERMINATION**
- 12.1 "Insolvent" means You ceasing to pay Your debts in the ordinary course of business or being unable to pay Your debts as they become due or You ceasing or threatening to cease to carry on Your business.
- 12.2 "Associated Company" means Your subsidiary or holding company as defined in Section 736 and Section 736A of the Companies Act 1985 or a subsidiary of such holding company, or any company over which Your directors or shareholders have control as defined in Section 840 of the Income and Corporation Taxes Act 1988.
- 12.3 If You fail to pay any invoice or any sum due to Us under any contract on the due date or Your credit limit is exceeded or You or Your Associated Company becomes Insolvent or there is a material change in Your or Your Associated Company's constitution or You commit a material breach of this contract and fail to remedy that breach within 2 working days of being requested to do so all sums outstanding between You and Us under this and any other contract shall become immediately due and payable and We shall be entitled to do any one or more of the following (without prejudice to any other right or remedy We may have):-
- (a) require payment in cleared funds in advance of further deliveries of Goods
 - (b) charge interest on the monies outstanding at the rate of 2% per month of the invoice price from the due date until date of payment after as well as before judgement
 - (c) suspend or cancel any further deliveries of Goods to You under any contract without liability on Our part
 - (d) suspend or cancel any obligation to install Goods whether under this or any other contract
 - (e) without prejudice to the generality of Clause 7 of these Terms exercise any of Our rights pursuant to that Clause; and/or
 - (f) terminate this or any other contract with You or any Associated Company without liability on Our part.
 - (g) insist upon an assignment of all rights, interests and causes of action You may have against Your customer or main contractor pursuant to the Contracts (Rights of Third Parties) Act 1999.
- 12.4 Except where You deal as a Consumer You shall reimburse Us costs including legal costs on an indemnity basis which We incur in enforcing Our rights under this contract including but not limited to recovery of any sums due.
13. **EXPORT TERMS**
- 13.1 Where the Goods are supplied for export from the United Kingdom the provisions of this Clause 11 shall apply notwithstanding any provision of these Terms.
- 13.2 In any case where Goods are sold CIF or FOB or on the basis of any other international trade term the meaning of such terms contained in Incoterms (1990) shall apply but if there is any conflict between the provisions of Incoterms and these Terms the latter shall prevail.
- 13.3 In the case of any sale of goods FOB We shall be under no obligation to give You notice specified in section 32(3) of the Sale of Goods Act 1979.
- 13.4 You shall be responsible for arranging for inspection of the Goods at Our premises before shipment.
- We shall have no liability for any claim in respect of any defect in the Goods which would have been apparent on inspection and which is made after shipment or in respect of any damage under transit.
- 13.5.1 Payment of all amounts due to Us shall be made by irrevocable letter of credit opened by You in favour of Us and confirmed by a United Kingdom clearing bank acceptable to Us or any other method of payment agreed by Us in writing by a Company Signatory.
- 13.5.2 Your order will not be accepted by Us until We have evidence of the letter of credit or bill of exchange as the case may be. All costs and charges incurred by us in negotiating and accepting payment methods shall be added to the price of the Goods.
- 13.5.3 This payment clause shall also apply if You are resident outside the United Kingdom.
14. **DISCLAIMER**
- 14.1 Prior to installation of the Glass Goods You may have requested that a Decorative Film is applied to the Glass Goods. The addition of a Decorative Film may reduce the safety aspects of the Glass Goods, therefore We advise You that a Clear Safety Film should also be applied to the Glass Goods.
- 14.2 If You purchase the Glass Goods from Us and You refuse to have a Clear Safety Film applied, then You must read and sign the Disclaimer. In the event that You refuse the application of a Clear Safety Film and You will not sign the Disclaimer then We will not apply Decorative Film to the Glass Goods for You.
15. **GENERAL**
- 15.1 This contract shall be governed and interpreted according to the Law of England and Wales and You agree to submit to the non-exclusive jurisdiction of the English Courts.
- 15.2 Any reference in these Terms to any Statute or Statutory Provision includes a reference to that Statute or Statutory Provision as from time to time amended extended or re-enacted.
- 15.3 The headings in these Terms are for convenience only and shall not affect their interpretation.
- 15.4 We shall not be liable for any loss or damage arising as a direct or indirect result of Our delay or failure to perform Our obligations under this contract by reason of any force majeure circumstances which shall include but not be limited to industrial action, import or export regulations or embargoes, difficulties in obtaining materials, parts components labour or fuel, power failure or breakdown in machinery or vehicles or other circumstance outside Our control.
- 15.5 The waiver by Us of any breach or default of these Terms shall not be construed as a continued waiver of that breach nor as a waiver of any subsequent breach of the same or any other provision.
- 15.6 If any clause or sub-clause of the Terms is held by a competent authority to be invalid or unenforceable the validity of the other clauses and sub-clauses of these Terms shall not be affected and they shall remain in full force and effect.
- 15.7 You hereby acknowledge that all intellectual property rights pertaining to any specifications, details and drawings prepared by Us in conjunction with any quotation or acceptance of an order, and any subsequent date specifically provided to You belong exclusively to Us and shall remain exclusive property.
- 15.8 We accept no responsibility, whether by reason of breach of contract, duty or in tort otherwise, for loss or damage to free issue materials or components supplied to it. Such materials or components are not insured by Us and You should therefore arrange adequate insurance cover.
- 15.9 No statement, description, information, warranty, condition or recommendation contained in any catalogue, price list, advertisement or communication or made verbally by any of Our agents or employees shall be construed to enlarge, vary or override in any way these Terms.
- 15.10 If the Housing Grants Construction & Regeneration Act 1996 Part II applies to this contract the Scheme under that Act shall apply and take precedence in the event of conflict between the Scheme and these Terms.
- 15.11 This contract is personal to You and it may not be assigned.
- 15.12 Termination of this contract shall not affect rights and obligations which have already accrued at the time of termination.
- 15.13 These Terms shall have precedence over any other contractual documentation you may receive or enter into with Us. If there are any inconsistencies between any documentation between Us and You these Terms shall have precedence.

Love the space you're in.

Sales Offices

Head Office – Horsham

Ashurst
Broadlands Business Campus
Langhurstwood Road
Horsham
West Sussex
RH12 4QP
Tel: 01403 390300
Fax: 01403 218828
E-mail: general@komfort.com

Leeds

Unit 2
Intermezzo Drive
Stourton Link
Leeds
West Yorkshire
LS10 1DF
Tel: 0113 395 6565
Fax: 0113 395 6566
E-mail: northern-sales@komfort.com

Birmingham

Unit 2
Rabone Park
Rabone Lane
Smethwick
Birmingham
B66 2NN
Tel: 0121 555 0300
Fax: 0121 555 0301
E-mail: midland-sales@komfort.com

Republic of Ireland

Tel: +353 (0)1 6099126
Fax: +353 (0)1 6099110
E-mail: dublin-sales@komfort.com

Southern Sales Counter

Unit 10
Gatwick Distribution Centre
Whittle Way
Crawley
West Sussex
RH10 9RT
Tel: 01293 577890
(for stock/sales counter enquiries only)

Internet

www.komfort.com

Showrooms

London

14 Bonhill Street
London
EC2A 4BX
Tel: 0207 256 5701
Fax: 0207 374 8649
E-mail: london.showsuite@komfort.com

Leeds

Unit 2
Intermezzo Drive
Stourton Link
Leeds
West Yorkshire
LS10 1DF
Tel: 0113 395 6565
Fax: 0113 395 6566
E-mail: leeds.showsuite@komfort.com

Scotland

The Skyhouse
18 Elliot Place
Glasgow
G3 8EP
Tel: 0113 395 6565
Fax: 0113 395 6566
E-mail: scotland.showsuite@komfort.com



Scan the QR code to automatically download Komfort's Head Office contact details direct to your smart device. To download a QR scanner visit the relevant app store to correspond with your device.

ID Number: KOMDOORSPL 06/12

Find us on:

Facebook  Twitter  You Tube 

www.komfort.com

Part of the Laidlaw Interiors Group